

# COPES-VULCAN AN SPX BRAND



## RAVEN™ Trim

### Superior RAVEN™ Concept — Proven Superior Technology

The RAVEN™ Control Valve was developed by highly experienced engineers who took the well-proven labyrinth disc stack type of trim and introduced two main patented innovations: resistance to the effects of blockage and reduction in noise. The innovative designs give this well-established technology for severe service applications even more technical advantages over other currently available trim designs.

### Resistance to the Effects of Blockage

The expanding passage design, combined with multiple entry points to the individual flow passages, make blockage very unlikely. Unlike conventional labyrinth trim designs, RAVEN™ has relief points built into the labyrinth design.

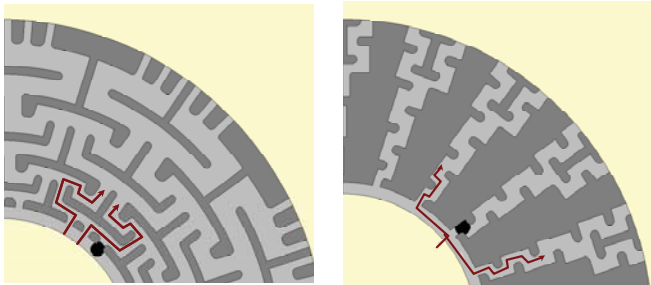

Under normal operation, these relief points have virtually no flow through them. In the event of blockage, the relief points are utilized. Extensive testing has shown that if a blockage occurs in RAVEN™ trim, all inlet ports and outlet ports are still utilized, minimizing any reduction in Cv and ensuring that the minimum designed number of pressure reducing stages are still used. In conventional labyrinth stack designs, a blockage in the stack eliminates the Cv of that path completely and in the case of a partial blockage, can actually generate noise.

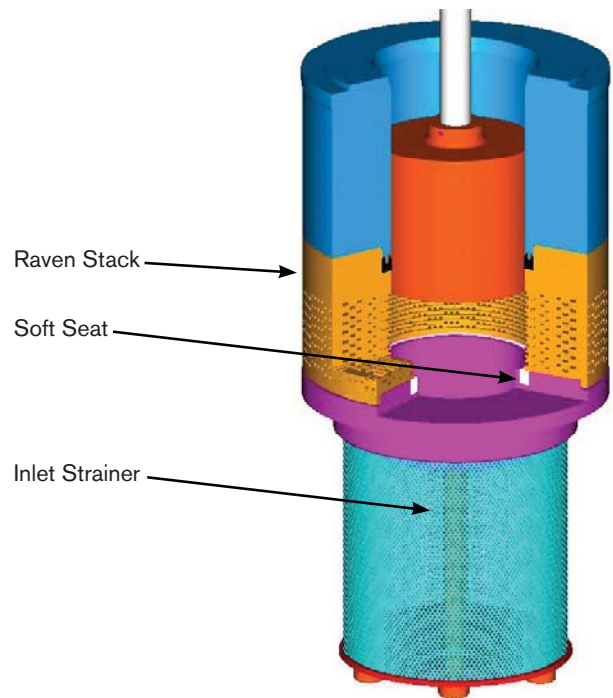

### Custom Designed for Each Application

Every RAVEN™ trim is custom designed to meet the needs to the toughest liquid, steam and gas services in the Oil and Gas, Petrochemical, Power and Process industries meeting NACE MR0175 where necessary. The number of pressure reducing stages is governed by two factors: velocity control and noise requirements. Either velocity or noise can be the factor determining the number of stages required. As per the latest ISA guidelines, RAVEN™ is designed to control velocity of the fluid within the trim to 100 ft./sec. (30m/s) (or the equivalent velocity head in case of gases). Dependent upon the differential pressure across the trim, the stages required to control the velocity are calculated. The lower the noise specification, the more stages required. The trim is also characterized to account for changes in flow and differential pressure at different valve openings.



## Velocity Control: Selection of Stages

Pressure Drop PSI	Fluid Velocity vs. Stages of Pressure Drop					
	1 Stage	3 Stages	4 Stages	6 Stages	10 Stages	16 Stages
500	220 fps	130 fps	100 fps			
1000	311 fps	184 fps	***	100 fps		
2000	440 fps	260 fps	***	***	100 fps	
4000	622 fps	368 fps	***	***	***	100 fps

### RAVEN Provides True Velocity Control

Copes-Vulcan's RAVEN™ Control Valves offer a proven solution for severe service applications where a true velocity control trim is the best, or possibly the only, answer. The combined effect of numerous narrow flow channels, each with many sharp turns and a continually expanding flow path, is to remove kinetic energy from the fluid while gradually lowering its pressure. By limiting the fluid velocities inside the valve, RAVEN™ trim precludes problems typically associated with high velocity such as erosion,

noise, vibration and poor control. The additional benefit for liquid flow is the elimination of cavitation and the damage it can do to a valve, its trim, and the downstream piping.

Due to the velocity control techniques utilized in RAVEN™, vibration can be virtually eliminated. High velocity is a root cause of noise and vibration, which often can cause seal failure, instrumentation problems and cracking of valve components.

### RAVEN™ Trim Design Criteria

Service Conditions	Kinetic Energy Criteria		Equivalent Water Velocity	
	psia	Kpa	Ft/sec	m/s
Continuous Service, Single Phase Fluids	70	450	100	30
Cavitating and Multi Phase Fluid Outlet (flashing)	40	275	75	23
Vibration Sensitive System	11	75	40	12

Flow can be either over or under the plug depending upon the fluid, the service and, in some instances, the piping configuration.

Equipped with various plugs (eg. unbalanced, balanced, tandem, etc.), RAVEN™ can provide shutoff classes ranging from ANSI/FCI 70-2 Class IV to VI and MSS-SP-61. For particular applications Copes-Vulcan can also supply our patented ZERO leakage design.

Quick-change design with no threaded or welded-in parts. Seat ring is a separate replaceable item.

A pressure-balancing groove inboard of the I.D. of each disc allows the plug to be completely balanced around its circumference, and provides a landing area for entrained debris, thus precluding plug galling. Additionally, bypasses in the flow path allow for entrained debris to clear the main fluid flow path.

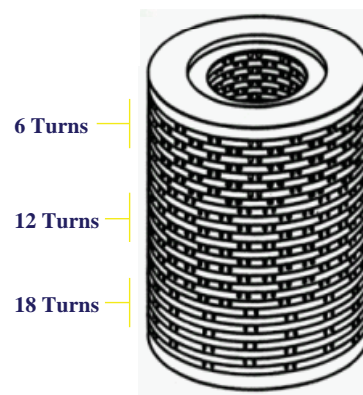

**SPX**®

**FLOW CONTROL**

Your local contact:



SPX Flow Control  
5620 West Rd.  
McKean, Pa 16426  
Phone: (814)476-5800 Fax: (814) 476-5848  
E-mail: cv@spx.com



For more information about our worldwide locations, approvals, certifications, and local representatives, please visit [www.spxfc.com](http://www.spxfc.com).

SPX Corporation reserves the right to incorporate our latest design and material changes without notice or obligation.

Design features, materials of construction and dimensional data, as described in this bulletin, are provided for your information only and should not be relied upon unless confirmed in writing.