

**DeZURIK**  
**COPES-VULCAN**  
A unit of **SPX** Corporation

**SAMN-U  
SPRING ASSISTED  
MULTIPLE NOZZLE  
DESUPERHEATER**

**DeZURIK/COPES-VULCAN**



## Operational Features

- Rangeability as high as 9:1
- Temperature control to within 15°F (8°C) of saturation with the ability to hold set point within a tolerance of 10°F (6°C)
- Standard maximum available Cv of 2.50 (Kv of 2.16); higher capacity available
- Available in standard classes 150, 300, 600, 900, 1500 and 2500 per ANSI B16.5
- Cooling water pressure minimum of 225 psi (1550 kPa) to a maximum of 1000 psi (6900 kPa) above the steam header pressure at the inlet
- Mounting commonality with 'U'-Series desuperheaters

## Description

The spring assisted multiple nozzle desuperheater reduces steam or gas temperatures by introducing cooling liquids directly into the hot fluid.

SAMN-U has six nozzles which can be opened or closed to vary the coolant flow. This provides a higher turndown than single nozzle units where the amount of coolant flow is dependent only on the ability to vary the pressure drop across the nozzle.

SAMN-U contains an integral spring loaded flow plug which moves in response to a change in pressure differential between the coolant inlet pressure and the main header pressure. As the plug moves, more or less nozzles are uncovered introducing more or less coolant into the main header. The varying inlet coolant pressure is controlled by a separate water or coolant control valve (usually supplied by DeZURIK/Copes-Vulcan).

The coolant enters the unit and passes through the center of the spring spacer, spring and plug. Unbalanced forces created by the coolant over line pressure differential cause the plug to move, exposing more or fewer flow nozzles. The coolant is atomized as it passes under pressure through the spray nozzles which further assist in evaporation of the coolant.

## Discharge Nozzles

The multiple nozzle arrangement located near the end of the nozzle tube is typically comprised of six individual nozzles. While in a standard unit, the six nozzles are all of the same size, seven nozzle size options are available. The nozzle size selected for a given application will maximize controller and turndown.

## Coolant Water Pressure

Coolant water pressure should be a minimum of 225 psi (1550 kPa) and a maximum of 1000 psi (6900 kPa) above the steam pressure during operation. Flow through the unit varies with water pressure. The plug begins to lift at approximately 60 psi (410 kPa) and reaches full travel at approximately 225 psi (1550 kPa) exposing all of the nozzles.

## Installation Recommendations

The SAMN-U can be furnished for installation in main stream line size 6–24" (150–600mm) and larger. It is recommended that the unit be installed in a header with a minimum of five pipe diameters [not less than 4' (1.2m)] of straight pipe upstream and 16' (5m) of straight pipe downstream.

The unit can be installed in either horizontal or vertical pipe run. For vertical pipe runs, it is recommended that flow is upward and a drain pot is placed at the bottom of the pipe run. All units must be installed such that the discharge nozzles face directly downstream. The recommended location of the temperature sensing point is 25' (8m) downstream.

The mounting interface is a standard 3" (80mm) flange per ANSI B16.5 at the rated pressure class. A 2.9" (74mm) minimum diameter bore is required for insertion into the header. The SAMN-U can be attached to the header by using a standard weld-o-let and weld neck flange for pressure classes 150–900. The mounting is usually supplied by others. Special fittings for mounting are available from DeZURIK/Copes-Vulcan for pressure classes 1500 and 2500 since weld reinforcement is required. Mounting gasket, studs and nuts are usually supplied by others.

# Dimensions

## 150 Pressure Class

Header Size	A	B	C	D
6" 150mm	12.06 306	7.69 195	6.19 157	8.69 221
8" 200mm	13.06 332	6.69 170	5.19 132	7.69 195
10" 250mm	14.12 359	5.62 143	4.12 105	6.62 168
12" 300mm	15.12 384	9.94 253	8.44 214	10.94 278
14" 350mm	15.75 400	9.31 237	7.81 198	10.31 262
16" 400mm	16.75 425	8.31 211	6.81 173	9.31 237
18" 450mm	17.75 451	7.31 186	5.81 148	8.31 211
20" 500mm	18.75 476	6.31 160	4.81 122	7.31 186
22" 550mm	19.75 502	5.31 135	3.81 97	6.31 160
24" 600mm	20.75 527	6.31 160	4.81 122	7.31 186

Inch  
Millimeter

## 300 Pressure Class

Header Size	A	B	C	D
6" 150mm	12.06 306	8 203	6 152	8.69 221
8" 200mm	13.06 332	7 178	5 127	7.69 195
10" 250mm	14.12 359	5.94 151	3.94 100	6.62 168
12" 300mm	15.12 384	10.25 260	8.25 210	10.94 278
14" 350mm	15.75 400	9.62 244	7.62 194	10.31 262
16" 400mm	16.75 425	8.62 219	6.62 168	9.31 237
18" 450mm	17.75 451	7.62 194	5.62 143	8.31 211
20" 500mm	18.75 476	6.62 168	4.62 117	7.31 186
22" 550mm	19.75 502	5.62 143	3.62 92	6.31 160
24" 600mm	20.75 527	6.62 168	4.62 117	7.31 186

Inch  
Millimeter

## Principle of Operation

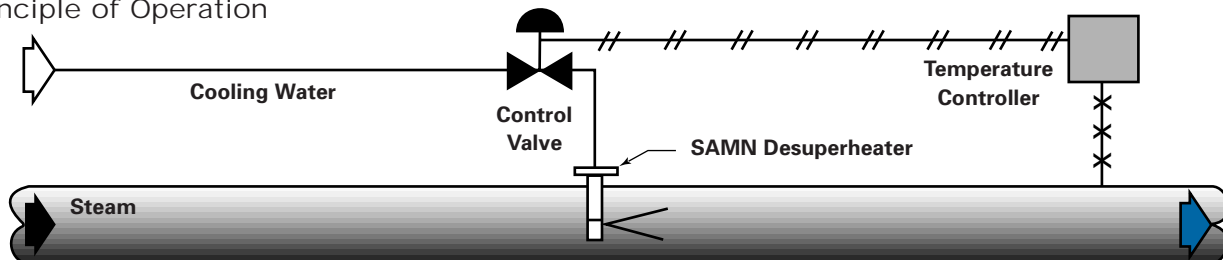

Temperature Controller sends signal to cooling water control valve, which in turn regulates flow of water to mechanical atomizing desuperheater.

## SAMN-U\*

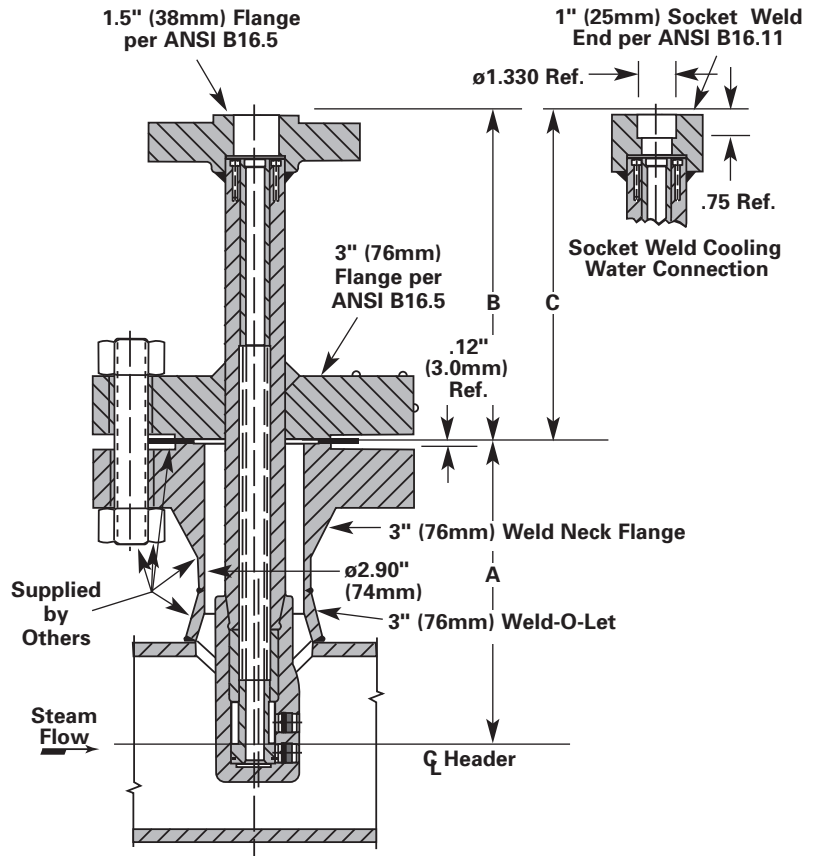

\* Low temperature configuration.

# Dimensions

## 600 Pressure Class

Header Size	A	B	C	D
6" 150mm	<u>12.06</u> 306	<u>8.31</u> 211	<u>5.62</u> 143	<u>8.69</u> 221
8" 200mm	<u>13.06</u> 332	<u>7.31</u> 186	<u>4.62</u> 117	<u>7.69</u> 195
10" 250mm	<u>14.12</u> 359	<u>6.25</u> 159	<u>3.56</u> 90	<u>6.62</u> 168
12" 300mm	<u>15.12</u> 384	<u>10.56</u> 268	<u>7.88</u> 200	<u>10.94</u> 278
14" 350mm	<u>15.75</u> 400	<u>9.94</u> 253	<u>7.25</u> 184	<u>10.31</u> 262
16" 400mm	<u>16.75</u> 425	<u>8.94</u> 227	<u>6.25</u> 159	<u>9.31</u> 237
18" 450mm	<u>17.75</u> 451	<u>7.94</u> 202	<u>5.25</u> 133	<u>8.31</u> 211
20" 500mm	<u>18.75</u> 476	<u>6.94</u> 176	<u>4.25</u> 108	<u>7.31</u> 186
22" 550mm	<u>19.75</u> 502	<u>7.94</u> 202	<u>5.25</u> 133	<u>6.31</u> 160
24" 600mm	<u>20.75</u> 527	<u>6.94</u> 176	<u>4.25</u> 108	<u>7.31</u> 186

Inch  
Millimeter

## 1500 Pressure Class

Header Size	A	B	C	D
6" 150mm	<u>12.06</u> 306	<u>8.81</u> 224	<u>5</u> 127	<u>8.69</u> 221
8" 200mm	<u>13.06</u> 332	<u>7.81</u> 198	<u>4</u> 102	<u>7.69</u> 195
10" 250mm	<u>14.12</u> 359	<u>6.75</u> 171	<u>2.94</u> 75	<u>6.62</u> 168
12" 300mm	<u>15.12</u> 384	<u>11.06</u> 281	<u>7.25</u> 184	<u>10.94</u> 278
14" 350mm	<u>15.75</u> 400	<u>10.44</u> 265	<u>6.62</u> 168	<u>10.31</u> 262
16" 400mm	<u>16.75</u> 425	<u>9.44</u> 240	<u>5.62</u> 143	<u>9.31</u> 237
18" 450mm	<u>17.75</u> 451	<u>8.44</u> 214	<u>4.62</u> 117	<u>8.31</u> 211
20" 500mm	<u>18.75</u> 476	<u>7.44</u> 189	<u>3.62</u> 92	<u>7.31</u> 186
22" 550mm	<u>19.75</u> 502	<u>8.44</u> 214	<u>4.62</u> 117	<u>8.31</u> 211
24" 600mm	<u>20.75</u> 527	<u>7.44</u> 189	<u>3.62</u> 92	<u>7.31</u> 186

Inch  
Millimeter

## 900 Pressure Class

Header Size	A	B	C	D
6" 150mm	<u>12.06</u> 306	<u>8.75</u> 222	<u>5.31</u> 135	<u>8.62</u> 219
8" 200mm	<u>13.06</u> 332	<u>7.81</u> 198	<u>4.38</u> 111	<u>7.69</u> 195
10" 250mm	<u>14.12</u> 359	<u>6.25</u> 171	<u>3.31</u> 84	<u>6.62</u> 168
12" 300mm	<u>15.12</u> 384	<u>11.06</u> 281	<u>7.62</u> 194	<u>10.94</u> 278
14" 350mm	<u>15.75</u> 400	<u>10.44</u> 265	<u>7</u> 178	<u>10.31</u> 262
16" 400mm	<u>16.75</u> 425	<u>9.44</u> 240	<u>6</u> 152	<u>9.31</u> 237
18" 450mm	<u>17.75</u> 451	<u>8.44</u> 214	<u>5</u> 127	<u>8.31</u> 211
20" 500mm	<u>18.75</u> 476	<u>7.44</u> 189	<u>4</u> 102	<u>7.31</u> 186
22" 550mm	<u>19.75</u> 502	<u>8.44</u> 214	<u>5</u> 127	<u>8.31</u> 211
24" 600mm	<u>20.75</u> 527	<u>7.44</u> 189	<u>4</u> 102	<u>7.31</u> 186

Inch  
Millimeter

## 2500 Pressure Class

Header Size	A	B	C	D
6" 150mm	<u>12.06</u> 306	<u>14.75</u> 375	<u>9.56</u> 243	<u>14.25</u> 362
8" 200mm	<u>13.06</u> 332	<u>13.75</u> 349	<u>8.56</u> 217	<u>13.25</u> 337
10" 250mm	<u>14.12</u> 359	<u>12.69</u> 322	<u>7.5</u> 191	<u>12.19</u> 310
12" 300mm	<u>15.12</u> 384	<u>11.69</u> 297	<u>6.5</u> 165	<u>11.19</u> 284
14" 350mm	<u>15.75</u> 400	<u>11.06</u> 281	<u>5.88</u> 149	<u>10.56</u> 268
16" 400mm	<u>16.75</u> 425	<u>10.06</u> 256	<u>4.88</u> 124	<u>9.56</u> 243

Inch  
Millimeter



250 Riverside Ave. N. • Sartell, MN 56377 • Telephone: 320-259-2000 • Fax: 320-259-2227

E-Mail: [info@dezurikcopesvulcan.com](mailto:info@dezurikcopesvulcan.com) • Web Site: [www.dezurikcopesvulcan.com](http://www.dezurikcopesvulcan.com)

*DeZURIK/Copes-Vulcan reserves the right to incorporate our latest design and material changes without notice or obligation. Design features, materials of construction and dimensional data, as described in this bulletin, are provided for your information only and should not be relied upon unless confirmed in writing by DeZURIK/Copes-Vulcan. Certified drawings are available upon request.*