

**COPES-VULCAN**  
AN SPX BRAND

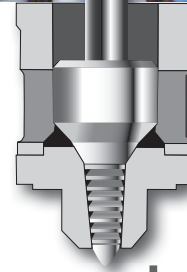

# Numbered Cascade Trim

## Application

Copes-Vulcan's Numbered Cascade Trim assembly is used in control valves where low flow rates and high turndown requirements prevail such as in desuperheater cooling water control, fuel oil control, blowdown and chemical feed.

The cascade trim can be applied when differential pressures are as high as 5000 psi (34,450 kPa) with service temperature as high as 1050°F (566°C).

Exceptional tight shutoff can easily be maintained.

## Function

A series of labyrinth grooves along the throttling surface of the plug provide a cascading effect so that the pressure drop is equally divided among the grooves, thereby reducing the seat wear that would normally be experienced if the entire pressure drop is taken across the seat. The cage guided tapered plug, in conjunction with the tapered cage bore, provides for maximum trim rangeability.

The plug and cage are designed so that metal-to-metal contact is made on beveled seating surfaces and the clearance between plug and cage tapers in the labyrinth groove section is held to .001" (.0254mm) for proper cascading effect.

For those applications where valve pressure decreases with increased flow, Numbered Cascade Trim is ideal. At light loads when pressure drop is maximum, the plug is close to the seat and the cascading has optimum effect. As load increases and pressure drop decreases, the need for cascading diminishes.

Since the total pressure drop is broken down into stages, erosion is held to a minimum, assuring that Numbered Cascade Trim will have a long service life.

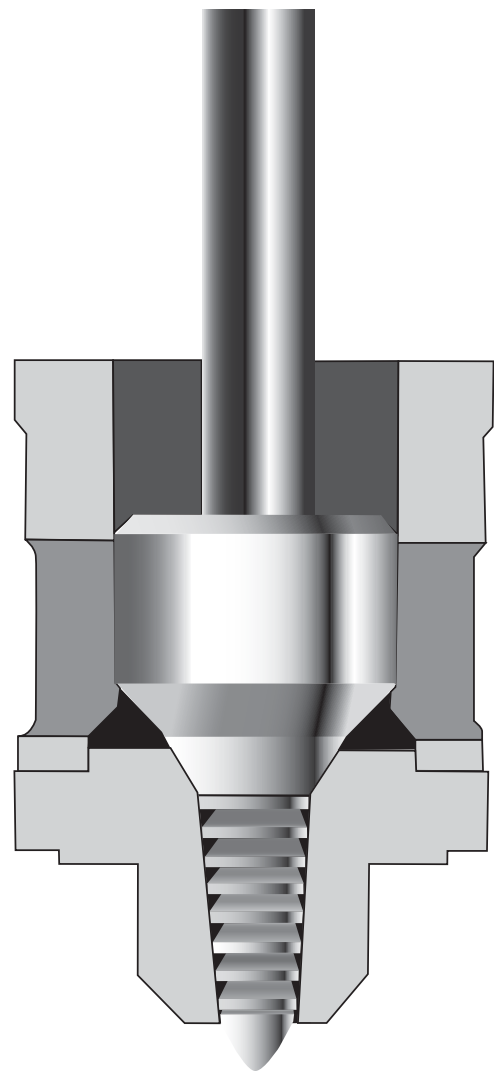

**SPX**®

## Features

Cage guiding, a Copes-Vulcan standard, includes a seating angle of 30° on the plug and 32° in the cage seat. Seat contact width is approximately .025" (.635mm). The valve actuator is selected to produce exceptionally tight seating under actual operating conditions. The high force produces a slight deformation of the seating surfaces, ensuring tight shutoff.

The cage and plug are made of ASTM A-479, Type 410 stainless steel with Rockwell C-34 to C-38 hardness. This material is highly resistant to erosion and has proven most suitable for the service.

Tape-controlled machining and well defined quality control measures ensure consistent conformance to Copes-Vulcan engineering specifications.

## Cv/Kv Factors Cascade Trim (Number Sizes)

Size	Cv/Kv
000	<u>.24</u> .21
00*	<u>.31</u> .27
0	<u>.37</u> .32
1	<u>.48</u> .42
2*	<u>.67</u> .58
3	<u>.88</u> .76
4*	<u>1.24</u> 1.07
5	<u>1.59</u> 1.38
6	<u>2</u> 1.73
7*	<u>2.9</u> 2.5
8	<u>4.1</u> 3.5
9*	<u>5.8</u> 5.0
10	<u>7.8</u> 6.7
11*	<u>9.9</u> 8.6

All Travels = 1" (25mm)

Note: \* on chart shows the only

Numbered Cascade Trim sizes available for Cv style bodies, including valve sizes .75" (20mm), 1" (25mm), 1.5"(40mm) and 2" (50mm).

All Numbered Cascade Trim sizes on chart can be used in body styles D, A and F in valve sizes through 2" (50mm). For larger trim sizes, refer to Bulletin CV-101.

ASTM A-479, Type 410 Stainless Steel is standard. Other materials available.

# SPX<sup>®</sup>

## FLOW CONTROL

Your local contact:



SPX Flow Control  
5620 West Rd.  
McKean, PA 16426  
Phone: (814)476-5800 Fax: (814)476-5854  
E-mail: cv@spx.com



For more information about our worldwide locations, approvals, certifications, and local representatives, please visit [www.spxfc.com](http://www.spxfc.com).

SPX Corporation reserves the right to incorporate our latest design and material changes without notice or obligation.

Design features, materials of construction and dimensional data, as described in this bulletin, are provided for your information only and should not be relied upon unless confirmed in writing.